

To measure current the circuit has to be broken and the meter connected in series. The break may be made anywhere within the circuit.

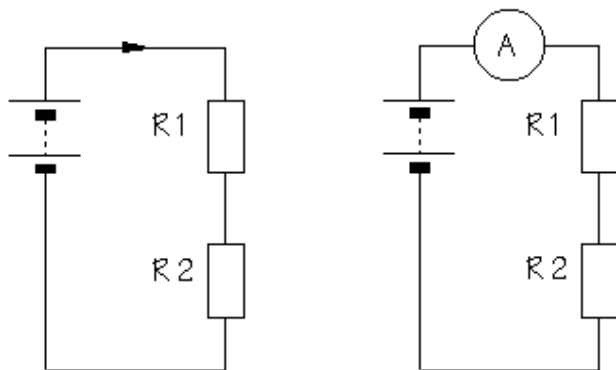

To measure resistance the component has to be isolated, or removed, from the circuit.

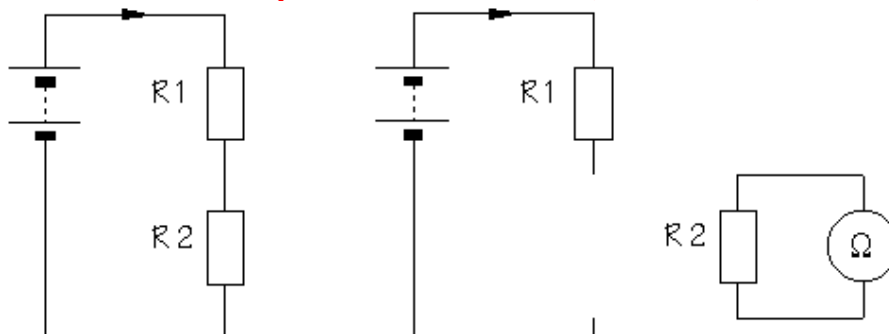

- The calculation of the Power consumption of a DC operated electrical appliance.

Power is measured in watts. It is voltage multiplied by the current.

$$W = V * I$$

KNOWLEDGE

To be verbally examined

- The cadet's understanding of Ohms Law.

$$V = I * R$$

TECHNICAL SKILLS – Ohm's Law Section

DESCRIPTIVE

Describe:

- The function of a diode within a circuit.
A diode is a component which will allow electricity to flow in one direction only. It may be used as part of a demodulator in an AM receiver.

AC Input

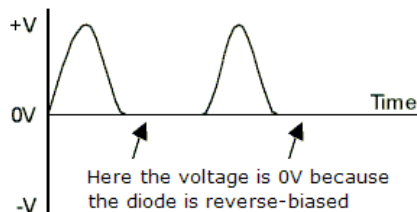
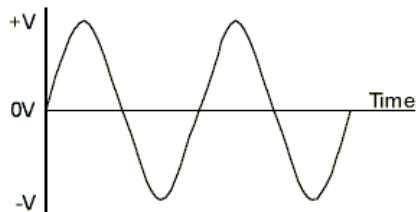

- The functions of a Multimeter.
A multimeter is used to measure various electrical quantities; mainly current (amps), voltage (volts), and resistance (ohms - Ω). Because of this it is often called an AVO meter.

DEMONSTRATIVE

Demonstrate:

- Using a Multimeter, in a simple low voltage circuit, for the measurement of voltage, current and the resistance of circuit components.

To measure voltage the meter is connected across the component without breaking the circuit.

